

# RCT 2299-2 - 2320-2

## Open koeltorens

### Technische gegevens

**REMARK:** Do not use for construction. Refer to factory certified dimensions & weights. This page includes data current at time of publication, which should be reconfirmed at the time of purchase. In the interest of product improvement, specifications, weights and dimensions are subject to change without notice.

#### General notes

1. Access door is always opposite to inlet connection end.
2. Alternative inlet/outlet and tower configurations are available.
3. Nominal outlet connection size provided.
4. Actual outlet sized to match flow.
5. Models RCT 2218-1 and 2129-1 have direct drive motors.
6. Models RCT 2218-2 and 2129-2 have direct drive motors.
7. Triple fan units are not available with common FRP basin. Only for installation on concrete basin.

**Laatst bijgewerkt:** 27/07/2024

#### RCT 2299-2 - 2320-2

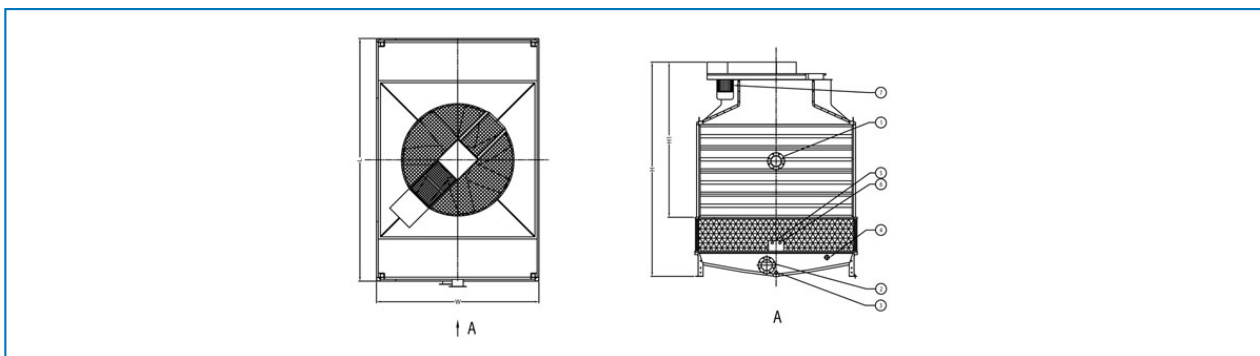

1. Waterinlaat; 2. Wateruitlaat; 3. Afvoer; 4. Overloop; 5. Make-up; 6. Snelle vulling; 7. Ventilatormotor.



Model	Gewicht (kg)			Afmetingen (mm)			Luchtdebiet (m <sup>3</sup> /s)	Ventilatormotor (kW)	Vloeistofinlaat ND (mm)
	Bedrijfgewicht (kg)	Transportgewicht (kg)	Zwaarste gedeelte (kg)	L	W	H			
RCT 2299-2	11450	4200	2100	6985	3499	4019	78.1	(2x) 15.0	(2x) 200
RCT 2320-2	11450	4200	2100	6985	3499	4019	83.5	(2x) 18.5	(2x) 200